

# **Mobile Network**

**E- Business Technology**

**Prof. Dr. Eduard Heindl**

**Shirin Faghihi**

No.232493

## **Table of content**

Glossary

1. Introduction
2. Four generation of mobile
  - 2.1. The first generation
  - 2.2. The Second generation
  - 2.3. The Third generation
  - 2.4. The Forth generation
3. Land line, Wireless and mobile networks
  - 3.1. Land line characteristic
  - 3.2. Wireless networks
    - 3.2.1. Cellular network
    - 3.2.2. Cordless telephony
    - 3.2.3. Wireless LANs
4. Mobile network
  - 4.1. Mobile devices
  - 4.2. Mobile Performance
5. Radio Fundamentals
6. GSM Network
7. The geographical network structure
  - 7.1. The network area
  - 7.2. The MSC / VLR service area
  - 7.3. Service area
  - 7.4. Location area
  - 7.5. The cell
8. Conclusion

## Glossary <sup>1</sup>

**GSM (Global System for Mobile communications)** is the most popular standard for mobile phones in the world. GSM is a cellular network, which means that mobile phones connect to it by searching for cells in the immediate vicinity.

**SS (switching systems)**: Telecommunications switching systems generally perform three basic functions: they transmit signals over the connection or over separate channels to convey the identity of the called (and sometimes the calling) address (for example, the telephone number), and alert (ring) the called station; they establish connections through a switching network for conversational use during the entire call; and they process the signal information to control and supervise the establishment and disconnection of the switching network connection.

**AUC (Authentication Center)** is a function to authenticate each SIM card that attempts to connect to the GSM core network (typically when the phone is powered on). Once the authentication is successful, the HLR is allowed to manage the SIM and services described above. If the authentication fails, then no services are possible from that particular combination of SIM card and mobile phone operator attempted

**Home location register (HLR)** is a central database that contains details of each mobile phone subscriber that is authorized to use the GSM core network. The main function of the HLR is to manage the fact that SIMs and phones move around a lot.

**Equipment Identity Register (EIR)** keeps a list of mobile phones which are to be banned from the network or monitored. This is designed to allow tracking of stolen mobile phones. In theory all data about all stolen mobile phones should be distributed to all EIRs in the world through a Central EIR.

**Visitor location register (VLR)** is a temporary database of the subscribers who have roamed into the particular area which it serves. Each base station in the network is served by exactly one VLR; hence a subscriber cannot be present in more than one VLR at a time. The data stored in the VLR has either been received from the HLR, or collected from the MS.

**Mobile Switching Center (MSC)** is the primary service delivery node for GSM, responsible for handling voice calls and SMS as well as other services (such as conference calls, FAX and circuit switched data). The MSC sets up and releases the end-to-end connection, handles mobility and hand-over requirements during the call and takes care of charging and real time pre-paid account monitoring.

**BSC (Base Station Controller)** provides, classically, the intelligence behind the BTSs. Typically a BSC has tens or even hundreds of BTSs under its control. The BSC handles allocation of radio channels, receives measurements from the mobile phones, controls handovers from BTS to BTS (except in the case of an inter-BSC handover in which case control is in part the responsibility of the anchor MSC).

---

<sup>1</sup> <http://www.answers.com> and <http://wiki.answers.com>

**BTS(Base Transceiver Station)** The base transceiver station, or BTS, contains the equipment for transmitting and receiving of radio signals (transceivers), antennas, and equipment for encrypting and decrypting communications with the base station controller (BSC).

**Integrated services digital network (ISDN)** is an international standard for switched, digital dial-up telephone service for voice and data. Analog telephones and fax machines are used over ISDN lines, but their signals are converted into digital by the ISDN terminal adapter.

**public switched telephone network (PSTN)** is the network of the world's public circuit-switched telephone networks, in much the same way that the Internet is the network of the world's public IP-based packet-switched networks. Originally a network of fixed-line analog telephone systems, the PSTN is now almost entirely digital, and now includes mobile as well as fixed telephones.

**Public land mobile network (PLMN)** is a network that is established and operated by an administration or by a recognized operating agency (ROA) for the specific purpose of providing land mobile telecommunications services to the public. A PLMNs interconnect with other PLMNs and Public switched telephone networks (PSTN) for telephone communications or with internet service providers for data and internet access.

## 1. introduction

Wireless and mobile networks are quickly becoming the main type of network access for telecommunication services. The progress trend of the wireless network and next generation mobile networks has now been directed into two distinct paths. One is following the path of the cellular mobile systems and their long-standing and much deployed infrastructure all over the world.

So Cellular telecommunication is one of the most developed and demandable transmittal usages.

Development of wireless access technologies is about to reach its fourth generation. In the past, a wireless access technology has followed different evolutionary Paths designed at combined target: performance and efficiency in high mobile environment.

The first generation has satisfied with the mobile voice, while the Second generation has introduced capability and coverage of mobile. This is followed by the third generation, which the mission of it was higher speeds in data to open the “mobile broadband” know-how. Broadband refers to an Internet connection that allows support for data, voice, and video information with high speeds connectivity such as DSL or cable services. On the one hand, it is considered broad because multiple types of services can travel across the wide band, and mobile broadband, on the other hand, pushes these services to mobile devices

## 2. Four generation of mobile<sup>2</sup>

2.1. The first generation of wireless technologies used analog broadcast, which operates in the 800-MHz band and uses 30-KHz channels using frequency division multiple access (FDMA). It was introduced in North America in 1985 as developed mobile phone service. As digital signals can be compressed, it enables more effective use of the frequency spectrum.

2.2. The second-generation systems digitize the control link and also the voice signal, which appeared in the early 1990s.this generation

---

<sup>2</sup> Mobile and wireless network by Dong-Wan Tcha, Encyclopedia of information systems, volume 3,copyright 2003,Elsevier science (USA)

supported voice, data, paging, and fax services. Moreover, they provide better quality and higher capacity by lower cost for customers.

- 2.3. The third generation of mobile phone technology enables the transmission of high-quality video images in the 2-GHz frequency band and realizes new mobile multimedia communications services. The universal mobile telecommunications system (UMTS) is a third generation mobile communications technology that provides wideband code division multiple access (CDMA) radio technology. With data rates up to 2 Mbps, UMTS provides increased capacity, increased data capability, and a far greater range of services. The CDMA technology offers higher-throughput, real-time services, and end-to-end quality of service (QoS), and is capable of delivering pictures, graphics, streaming video, video messaging to location services, and other multimedia information as well as voice and data to mobile wireless subscribers.
- 2.4. The fourth generation of mobile services is the advanced version of the third generation mobile communication services. The fourth generation mobile communication services provide broadband, large-capacity, high-speed data transmission, providing users with high-quality interactive multimedia services, including teleconferencing, color video images, 3D graphic animation games, and audio services. In addition, 4G networks are expected to offer global mobility, service portability, and scalability at lower cost. They are based on orthogonal frequency division multiplexing (OFDM), which is capable of having hundreds of parallel channels. The data-transmission rates are planned to be 20 to 100 Mbps in mobile mode.<sup>3</sup> This technology allows seamless merging between different wireless standards, allowing one mobile device to move from indoor networks such as wireless LANs and Bluetooth, to cellular, to radio and TV broadcasting or to satellite communications.

---

<sup>3</sup>(<http://www.mobileinfo.com/3G/4GVision&Technologies.htm>)

### 3. Land line, Wireless and mobile networks <sup>4</sup>

There are four different characteristics between landlines and cell phones.

#### 3.1. Land line characteristic

In the land line the identity of user is apparent because the telecommunication organization connect two copper wires to the place that user asks for the number .so the first level in communication web is *identity* of the users. *Location* is the second item which is apparent in landline, too. It means that everyone can call the number which is registered in switch. Next step is charging which is registered in user switch and by that switch the cost that user have to pay will be accounted. The extra services like monitoring the other numbers or conversation transfer or etc, are written and registered in the same switch. So generally landline network has the following characteristics that cell phones do not have: <sup>5</sup>

- Exact identity
- Exact location
- One switch for charging
- Extra services from the same switch

#### 3.1. Wireless and mobile networks

Wireless and mobile networks, since their infrastructure domains, particularly the core domain, are not significantly different from one another, are generally classified according to the air interface into the following steps:

- 3.1.1. Cellular network: a cellular network, in comparison with its predecessor with a single large zone, consists of many cells with small coverage .each frequency channel is used repeatedly by multiple cells, sufficiently far apart to be interference tolerance

---

4 .(Persian book) Mobile network by Sohrab Niazi (2009).www.niazisoft.blogfa.com

<sup>5</sup> .Mobile and wireless network by Dong-Wan Tcha, Encyclopedia of information systems, volume 3,copyright 2003,Elsevier science (USA)

from each other. This frequency reuse is a key enabler to support a huge number of subscribers. The hand-off instrument is another important characteristic, by which the frequency assigned for a cells seamlessly changed as the MT crosses cell boundaries. This requires the MT to frequently change frequencies as needed.<sup>6</sup>

3.1.2. Cordless telephony: Cordless telephony is basically not much different from the cellular system, but more characterized by low mobility (small range and low user speed) and small power. starting from a simple application at private residence. it has evolved to a telephone access system supporting the unidirectional calling capability only. Customer needs transformed the system to have two-way calling capability and a wide service area was partitioned into a number of small cells, rendering the systems to have similar characteristics with the cellular network above.<sup>7</sup>

3.1.3. Wireless LANs: WLANs (Wireless LANs) prefers to their wired counterparts for situations in which wiring is difficult or impractical, or some degree of mobility is needed. many of WLAN standards use the ISM band, and some architectures even support short-term implementation, whereby terminals communicate directly with each other (peer to peer) without the mediation of fixed base station. a group of WLANs under the common architecture can form a large logical network with a wide service area, in which case mobility management becomes a key issue.<sup>8</sup>

---

6 .Mobile and wireless network by Dong-Wan Tcha, Encyclopedia of information systems, volume 3,copyright 2003,Elsevier science (USA)

7 . Wireless internet by Abbas Jamilpour, handbook of technology management, Wiley 2009,Hossein Bidgoli (editor in chief)

8 .Wireless internet by Abbas Jamilpour, handbook of technology management, Wiley 2009,Hossein Bidgoli (editor in chief)

#### 4. Mobile network<sup>9</sup>

Wireless mobile networks have ever-changing topologies, mostly composed of bandwidth-constrained wireless link. It equipped with wireless transmitters and receivers, sometimes with a platform like a router.

4.1. Mobile devices such as smart phones and personal digital assistants have reached new levels of usability, performance, and computing power. Increasingly, these devices are equipped with wireless-communications capabilities and location technologies. In mobile network there is a device like wireless phone and the account is registered in a module by the name of (SIM) card (Subscriber Identity Module card). So after entering the card in the mobile phone, network starts to check the validity of the (SIM) card by verification procedure which connects to an authentication center. Mobile phones are portable and their Size, weight and battery life are the other performance parameters of mobile phones and recent technologies that makes these phones to be smaller

#### 4.2. Mobile Performance

Under conditions ranging from moderate to good, the speech quality in GSM system is comparable by analog systems, but under bad conditions which relates to weak signals or Interference, GSM systems show better quality.

#### 5. Radio Fundamentals<sup>10</sup>

There are many radio transmission technologies, which can be grouped into two lines, ones associated with spectrum issues and the others with transmission technologies. Radio systems don't work with cables and use radio equipment to send the information.

Frequency spectrum is a scarce resource to be efficiently used. For system design, three important issues must be considered:

- regulation on the use of the band of interest

---

<sup>8</sup> Hand Book of Computer Networks, Hossein Bidgoli, (Editor In Chief), 2007, Wiley (USA), Volume II, Part 3, Arne Mämmelä, Cellular and Wireless Networks, Chapter 97

<sup>10</sup> Mobile and wireless network by Dong-Wan Tcha, Encyclopedia of information systems, volume 3, copyright 2003, Elsevier science (USA)

- Spread characteristics such as reduction, reflection and multi path behavior and technological impact on equipment like antennas and transceivers.
- Whether both up and downlink transmissions are provided via a paired band allowing frequency division duplex (FDD) or via a single band only, thus restricted to time division duplex (TDD). A general trend on the spectrum issues is that as the frequency increases, more expensive technology is required from the increase in spread attrition.

Communications in a mobile system require BTS (Base Transceiver Station) and MS (mobile station) which by using frequency, information transmit to MS. In broadcasting only one user can exist in a system to send information unilateral in the downlink path and another one in uplink path, this condition is called simplex with the channel being called duplex. The frequency of uplink and downlink is always the same to shun the problems and interferences. This space is called duplex distance or double.

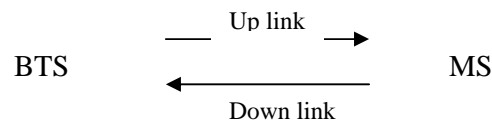

## 6. GSM Network<sup>11</sup>

Basically Global System for Mobile communications (GSM) divides in two main parts, switching system and base station system.

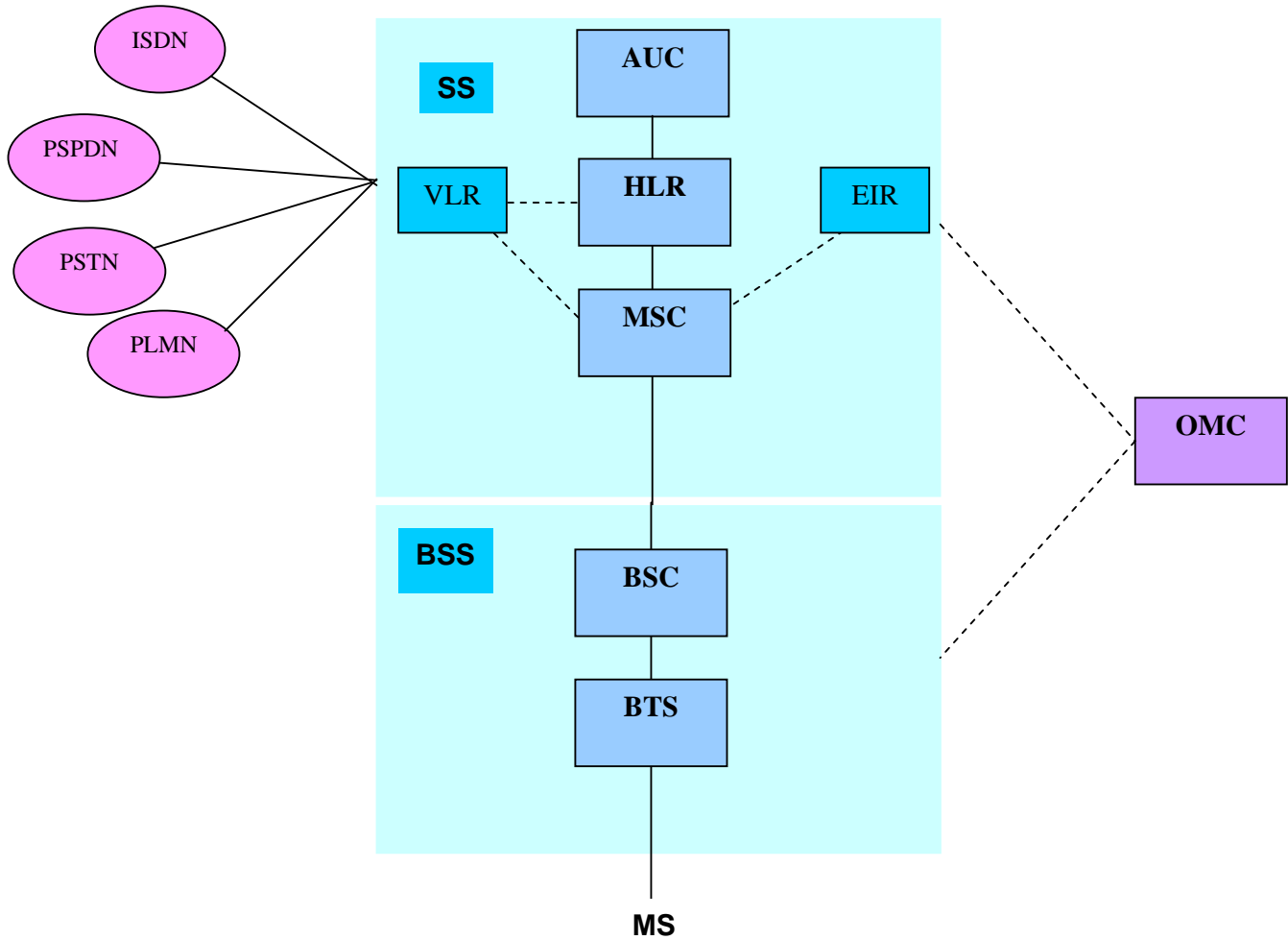

GSM system model

ISDN integrated services digital network  
PSPDN Packet-Switched Public Data Network  
PSTN public switched telephone network  
PLMIN public land mobile network

Both SS and BSS systems are divided into numbers called work units and these units do all the functions related to the system.

<sup>11</sup> (Persian book) Mobile network by Sohrab Niazi (2009).[www.niazisoft.blogfa.com](http://www.niazisoft.blogfa.com)

Switching systems (SS) contains:

- AUC (Authentication Center)
- HLR (Home Location Register)
- MSC (Mobile Service Switching Center)
- EIR(Equipment Identity Register)
- VLR (Visitor Location Register)

There are two types of location registers: home location register (HLR) and visitor location register (VLR). HLR is a database for mobile subscriber management. Stored within are subscription information and routings. At least one identity attached to each subscriber and piece of equipment should be kept, respectively, at the authentication center (AUC) and at the equipment identity register (EIR), usually located in HLR. Mobile terminals (MTs) roaming in an MSC area which will be defined shortly, are tracked by the VLR in charge of the area. When an MT enters a new location area, it starts a registration procedure by reporting this to the VLR. If this MT is not yet registered, the VLR and the HLR exchange the information required for the proper call management. The information for the calls set up or received by the MTs in an MSC area is stored in the database of the VLR. For some supplementary services other than the routine call management, a VLR may have to obtain additional information from the HLR.

A VLR may be in charge of one or several MSC areas. (MSC) Mobile Service Switching Center is an exchange which performs all the switching and signaling functions for MTs is located in an area, called an (MSC) area which is referred to as the mobile service switching center. It, unlike an exchange in a fixed network, should consider the scarcity and propagation characteristics of radio spectrum, based on such key procedures as location registration and hand off should be managed<sup>12</sup>. The (MSC) should be equipped with a functional entity designated as the inter working function (IWF), which allows

---

<sup>12</sup> Hand Book of Computer Networks, Hossein Bidgoli, (Editor In Chief), 2007, Wiley (USA), Volume II, Part 3, Arne Mämmelä, Cellular and Wireless Networks, Chapter 97.

inter working, via protocol conversion, between a radio network and the existing fixed networks.<sup>13</sup>

BSS Contains:

- BSC (Base Station Controller)
- BTS(Base Transceiver Station)

A System known as a network of radio cells which are close to each other and makes service area. Each cell has BTS which operates on a set of radio channels. For preventing interference in the neighboring cells, different channels are used and a group of (BTS) is controlled by one (BSC).

BTS also can be a controller of some functions like handover. All the mentioned units responsible for making connection between MS and for example PSTN .The first item for starting a connection is to know where the user who we want is and because of this requirement, database network is needed. This database always remains the MS situation. The most important database is HLR. When a person joint to GSM operator, the information registered in relate HLR.HLR contains information of a user like facilities, and relate parameters about the identity. The information change when the user moving . MS send his location's information to HLR by MSC/VLR.

The other unit is AUC which relates to HLR .the duty of AUC is preparing the parameters which relate to ciphering key and identity for HLR.

VLR is a unit by a data bank from the information about the all MS's location that are in MSC area.VLR which is connect to MSC ask HLR for some information about MS.in that time HLR inform about MS location it means about its location in MSC.After that, if MS want to call, VLR has all the information without asking HLR.

---

<sup>13</sup> Mobile and wireless network by Dong-Wan Tcha, Encyclopedia of information systems, volume 3,copyright 2003,Elsevier science (USA)

## 7. The geographical network structure<sup>14</sup>

Each telephone network need the distinct structure to make a path for all the connection .this structure in mobile network is so important because all the users usually change their location.

### 7.1 The network area

The link between GSM network and the other network like PSTN, ISDN or PLMN are in the international level. All the enter connection for a GSM / PLMN lead to one or some GMSC. GMSC acts as a transit center for PLMN /GSM. This center leads all the connection to the exact path so enable the systems to find the right and exact path.

### 7.2. The MSC / VLR service area

One MSC area shows the part of network which is cover by one MSC. To lead a connection to a user, the network internal path, connect to MSC in a MSC area which is the user in.

### 7.3. Service area

Service area is a part of network that defines as an area which can access to one MS because this MS registered in one VLR. It's better to say that each area of MSC complete with one VLR and make a service area.

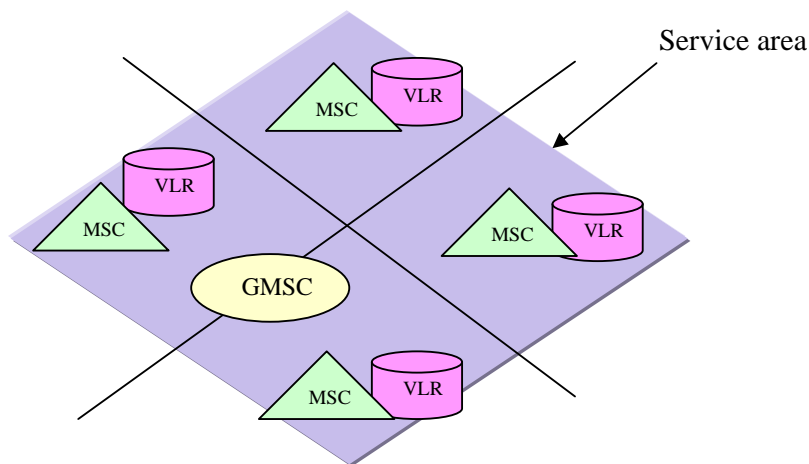

MSC / VLR area services

<sup>14</sup> Mobile and wireless network by Dong-Wan Tcha, Encyclopedia of information systems, volume 3, copyright 2003, Elsevier science (USA)

#### 7.4. Location area

Each MSC /VLR services area divide to some parts. Each LA is part of one MSC / VLR service area that one mobile or user can move easily without need to update its location's information.

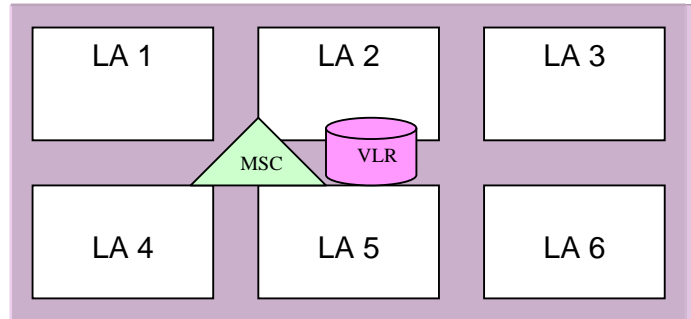

The division of a MSC / VLR Service area Into Location Area

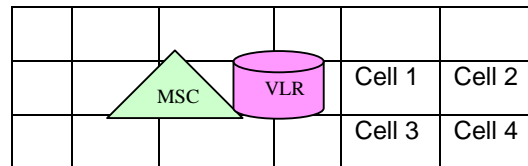

LA is also an area that run a paging message to find a user .each LA can have so many cells that may belongs to one or several BSC but all of them are for just one VLR /MSC.<sup>15</sup>

<sup>15</sup> Hand Book of Computer Networks, Hossein Bidgoli, (Editor In Chief), 2007, Wiley (USA), Volume II, Part 3, Aarne Mämmelä, Cellular and Wireless Networks, Chapter 97

### 7.5. The cell

Each LA divides to several cells. Each cell is an area with radio cover that network define its identity with CGI (cell global identity).MS by using BSIC (base station identity code) makes difference between the cells which use the frequency of similar users.<sup>16</sup>

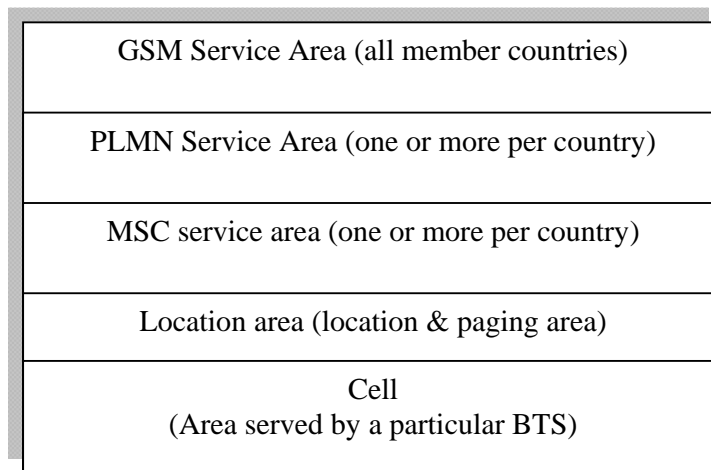

Relation between areas in GSM

---

<sup>16</sup> Mobile and wireless network by Dong-Wan Tcha, Encyclopedia of information systems, volume 3, copyright 2003, Elsevier science (USA)

## 8. conclusion<sup>17</sup>

this paper reviewed the most common example of a cellular network which is a mobile phone (cell phone) network. A mobile phone is a portable telephone which receives or makes calls through a cell site (base station), or transmitting tower. Radio waves are used to transfer signals to or from the cell phone. Great geographic areas may be split into smaller cells to avoid line-of-sight signal loss and the large number of active phones in an area. As the phone user moves from one cell area to another cell, the switch automatically commands the handset and a cell site with a stronger signal (reported by each handset) to switch to a new radio channel (frequency). When the handset responds through the new cell site, the exchange switches the connection to the new cell site.

---

<sup>17</sup> <http://www.answers.com>

## References

- Mobile and wireless network by Dong-Wan Tcha, Encyclopedia of information systems, volume 3, copyright 2003, Elsevier science (USA)
- (Persian book) Mobile network by Sohrab Niazi (2009). [www.niazisoft.blogfa.com](http://www.niazisoft.blogfa.com)
- Hand Book of Computer Networks, Hossein Bidgoli, (Editor In Chief), 2007, Wiley (USA), Volume II, Part 3, Arne Mämmelä, Cellular and Wireless Networks, Chapter 97.
- (<http://www.mobileinfo.com/3G/4GVision&Technologies.htm>).
- Wireless internet by Abbas Jamilpour, handbook of technology management, Wiley 2009, Hossein Bidgoli (editor in chief)
- <http://www.answers.com>